

JACKSONVILLE  
**HOME  
+ PATIO  
SHOW**

# EXHIBITOR MANUAL

## PRIME OSBORN CONVENTION CENTER



## September 30th – October 3, 2021

This Exhibitor Manual has been compiled to help you and your staff with complete details about all phases of the exhibition process at the Jacksonville Home and Patio Show

Enclosed you will find helpful information to make your participation in our show successful.

**We strongly urge that you give this manual to those having responsibility for your participation in the show.**

[JacksonvilleHomeShows.com](http://JacksonvilleHomeShows.com)

**MARKETPLACE | EVENTS**  
Largest Home Show Producer | in North America

# SHOW MANAGEMENT

The Jacksonville Home + Patio Home Show is produced and managed by:

Marketplace Events  
2000 Auburn Drive  
Suite 200  
Beachwood, OH 44122

Tina Robinson, Show Manager  
P: 904-622-9140  
[TinaR@MPEshows.com](mailto:TinaR@MPEshows.com)  
[www.marketplaceevents.com](http://www.marketplaceevents.com)

---

# SHOW FACILITY

The Jacksonville Home + Patio Show is held at the Prime Osborn Convention Center.

1000 Water Street  
Jacksonville, FL 32204  
P: 904-630-4800  
[www.JaxEvents.com](http://www.JaxEvents.com)  
Whitney Gordon, Event Manager  
[WGordon@SMGJAX.com](mailto:WGordon@SMGJAX.com)

---

# UTILITIES

Electricity, Telephone, Water, etc.  
These services are provided by the Prime Osborn Convention Center.  
Main: 904-630-4000  
Fax: 904-630-4029

Advance Order Deadline: September 10, 2021

# MOVE-IN | MOVE-OUT DAYS AND HOURS

## ALL ACCOUNTS MUST BE PAID IN FULL BEFORE YOU MOVE-IN

For safety reasons, no one under the age of 16 is permitted in the halls or dock areas during move-in/out.

---

### General Move-In Dates/Time

Tuesday	September 28, 2021	8:00am - 5:00pm
Wednesday	September 29, 2021	8:00am - 5:00pm

*The following booths cannot move in until the dock doors are closed on Wednesday afternoon: N/A for Fall 2021 Show*

*Please check with your sales consultant for exact times.*

Dock doors will close at 5pm on Tuesday and Wednesday. Exhibitors can enter through the security entrance (Door 1) until 7pm. **Move-in must be completed by Wednesday, September 29, 2021.**

Forklifts are available to assist with move-in. Check in with Show Decorator to arrange forklift or cart service.

Exhibitors must use Door 1, Door 6, and Door 7 to access the show floor during move in. Please do not use any other doors. Propping doors open is strictly prohibited.

---

### General Move-Out Dates/Time

Sunday	October 3, 2021	6:01pm - 10:00pm
Monday	October 4, 2021	8:00am – Noon

**At 6:01pm on Sunday, aisle carpet in section six must be rolled up before any carts or vehicles can be used in the building. Stay off the aisle carpet in section 6 (including items you are dismantling and packing from your booth); it will make things go a lot faster for everyone.**

All exhibit material must be out of the convention center by noon on Monday, October 4, 2021. Your space must be clean of all debris. If any materials are left behind, your company will be subject to a removal and cleaning fee. Marketplace Events is not responsible for any materials that are left in the building. All pavers and pallets must be removed from parking lot by Monday, October 4, 2021 at 5pm. No exceptions. **Materials not removed by this time are subject to handling fines. You may use your own carts, hand trucks, dollies, etc. Dismantling your booth prior to show close at 6:00pm on Sunday is strictly prohibited.** This is a serious safety issue for our attendees and extremely discourteous to your neighboring exhibitors who are trying to conduct business. Do not break down early.

## SHOW HOURS

Thursday	September 30, 2021	11:00am – 9:00pm
Friday	October 1, 2021	11:00am – 9:00pm
Saturday	October 2, 2021	10:00am – 9:00pm
Sunday	October 3, 2021	10:00am – 6:00pm

Exhibitors may enter the show one hour before opening through the Exhibitor Entrance.

---

## EXHIBITOR BADGES

Exhibitor badges are NOT mailed out prior to the show. Badges can be picked up in the Show Office Room 106 which is downstairs during move-in & during the show. Plastic badge holders are provided.

Exhibitor badges are required to identify you as an authorized exhibitor. Exhibitors will not be allowed access to the show floor during show days without a badge.

Six (6) exhibitor badges are provided for each 100 square feet of space purchased, with a maximum allotment of 24 badges per company.

If you have different staff members working your booth on different days, you are encouraged to drop off your badge each night at the exhibitor check-in desk so that your company does not run out of badges during the show.

Exhibitor badges must not be used as admission tickets and cannot be left at Will Call. The Exhibitor Entrance opens one hour prior to the show opening each day.

---

## SHOW OFFICE

During move-in, show hours & move-out, Show Management will maintain an office in the Convention Center. The office is located in meeting room 106 downstairs. Look for the show office sign.

## EXHIBITOR ENTRANCES DURING SHOW HOURS

During show hours, exhibitors may use Door #7 which is adjacent to the parking lot on the side of the building or the Exhibitor Entrance which is located across the courtyard to the left of the main entrance. Follow the signs to this entrance and/or refer to the show floor plan. An exhibitor badge will be required to enter the show floor. **Prime Osborn Convention Center Security requires bag check to enter the building during show days.**

The main entrance is for attendees and gets very crowded prior to opening each morning. You will not be allowed to bring in exhibit supplies through this entrance, including hand-carried items.

---

## COMPLIMENTARY TICKETS

**\*\*\*NEW FOR 2021\*\*\*** Each exhibitor will receive online ticket redemption codes valid for 25 complimentary tickets to the show. These will be emailed out three weeks prior to the show. Tickets will only be emailed out if your account has been settled in full. Pass your unique code along to your customers, who can go online and use it as a coupon code to redeem free tickets to the show using our eTicketing system. If you do not receive your tickets or you would like to request more, contact [erinc@mpeshows.com](mailto:erinc@mpeshows.com).

If you wish to leave tickets at Will Call, you may redeem and print tickets using your unique code. See Will Call section below for how to leave them for your guests at the show.

**Complimentary tickets are not permitted to be distributed at the entrance of the show.** Use your tickets to invite potential customers to the show, as a thank you to good customers or for friends and family.

---

## PROMOTIONAL ITEMS

We encourage exhibitors to give out promotional items at the show to market to attendees; however, due to the venue's policies, the following are not permitted:

- Alcohol as a promotional item (ex. having a "happy hour" in your booth or giving out glasses of wine)
- Any food or beverage distribution as a promotional item (ex. branded water bottles, cookies, candy, etc)
- Stickers and helium balloons are discouraged as they create a problem for the facility to clean up and you may be charged a cleanup fee (ex. sticker removal or balloons being stuck in the ceiling)

Branded totes, pens, cups, etc are welcome! The best way to promote your services is to post show specials on your Exhibitor Listing on our website for attendees to see before, during, and after the show. Promotional items are not allowed to be distributed anywhere at the show except your booth; speak to your Exhibit Sales Consultant if you are interested in a front entrance sponsorship, stage sponsorship, or feature sponsorship for additional exposure!

## **WILL CALL**

Will Call will be set up at the main entrance of the show in the box office. Please leave your tickets in INDIVIDUALLY marked envelopes with FIRST AND LAST NAME on the front of the envelope at Will Call for your guests. Exhibitor Badges are not to be left at Will Call; they can be left at the Show Office in Room 206 for your staff working your booth only (not as tickets to the show for attendees).

---

## **DECORATOR SERVICES**

Veal Convention Services is the show decorator and provides carpet, tables, chairs, cleaning, signage, etc. Please order these items directly from them. The forms are available on our website [www.JacksonvilleHomeShows.com](http://www.JacksonvilleHomeShows.com) under "Exhibitor Kit" at the bottom of the home page.

---

## **UTILITIES AND SERVICES POLICY**

The Prime Osborn Convention Center is happy to provide utilities and services at prevailing rates. Current rate sheets for labor, equipment rental and services are available on request. For safety reasons, Prime Osborn Convention Center personnel must perform installation of all utility services.

Please submit all service order forms with full payment enclosed to the Prime Osborn Convention Center. They cannot provide the service until payment is received. To receive the lower advance rate, your forms must be received 7 business days prior to your first scheduled show day.

---

## **FOOD AND BEVERAGE SAMPLING**

All food sampling must be approved by Savor Jacksonville. Beverage sampling is limited to 4oz and food samples are limited to 2oz. A written description that outlines the product and portion size to be sampled shall be submitted in advance to Savor Jacksonville.

Forms for all the above services can be found on our website [www.JacksonvilleHomeShows.com](http://www.JacksonvilleHomeShows.com)  
Click on "Exhibitor Kit" at the bottom of the homepage.

# VEHICLES IN EXHIBITS

If you plan on having a vehicle in your booth as part of your display, please contact Show Management for approval and move-in instructions.

- Visqueen must be put down on the floor before the vehicle is driven into place.
- All vehicles must have a locking gas cap or gas cap sealed with tape and no more than 1/4 tank of gas in the vehicle.
- A set of keys must be left with Show Management for the duration of the show.
- All vehicle batteries must be disconnected and cables taped.

---

## BOOTH INFORMATION, RULES & REGULATIONS

Exhibit booths will have an 8' draped back wall. On each side, a draped side rail will extend from the back of the booth to the front of the booth at a height of 32". The drape color is black. Tables, chairs, electricity etc. are not included with the cost of your exhibit booth.

### Flooring

Flooring is not included in the cost of your exhibit booth. Carpet tape must be approved and be easily removable. The show decorator will provide approved carpet tape upon request. Sections 1 -5 are carpeted areas of the convention center. All pavers and hard surface flooring must be placed on top of visqueen over carpet. For those exhibitors booked in Section 6 it is mandatory that all exhibit booths are carpeted or have some type of clean, professional-looking floor covering that covers 100% of the booth's square footage. All pavers and hard surface flooring must be placed on top of visqueen.

### Table Skirting

It is mandatory that all tables are properly skirted. Skirting must go from the edge of the table to the floor on all four sides. All skirting must be pressed and neat. Use of plastic table cloths, sheets, shower curtains or any type of "makeshift" table cloths is not permitted. We strictly enforce this and will skirt all incorrectly skirted tables at the exhibitor's expense.

All inventory and personal items must be stored completely out of sight. Your booth should look professional and inviting to the attendee.

### Staffing Your Booth

All exhibitors are expected to be in their booths during all published show hours, as we do receive consumer complaints about un-manned displays. Our visitors pay an entrance fee and expect to be able to do business with our exhibitors at any time during show hours. If you are in violation of this rule, your company may not be permitted to exhibit with us in the future.

Working in the aisles or distributing brochures, etc. from any other area other than your booth is prohibited. All activity must take place inside your contracted space.

# \*\*\*TENTS ARE NOT ALLOWED\*\*\*

## Booth Guidelines

Exhibitors are allowed to build their booth to the maximum height of 8 feet. This includes back wall and sidewalls. If your display includes a sign attached to the back wall, you must get approval from show management and the following rules apply:

- Total height of sign must not exceed two feet from top of drape line
- Sign must be single-sided
- Professionally finished (no raw plywood, exposed wiring, etc may be showing from any side as a courtesy to your neighboring booths)
- No PVC pipe allowed
- No marketing materials (teardrop flags, banners, etc.) above 10' are permitted. Air rights may be purchased depending on booth size; contact your sales consultant for review, approval, and applicable fees.

If you are using side walls as part of your display they must be completely finished on BOTH sides. No exposed wires, frames, wood must be exposed for the public or your neighbor to see.

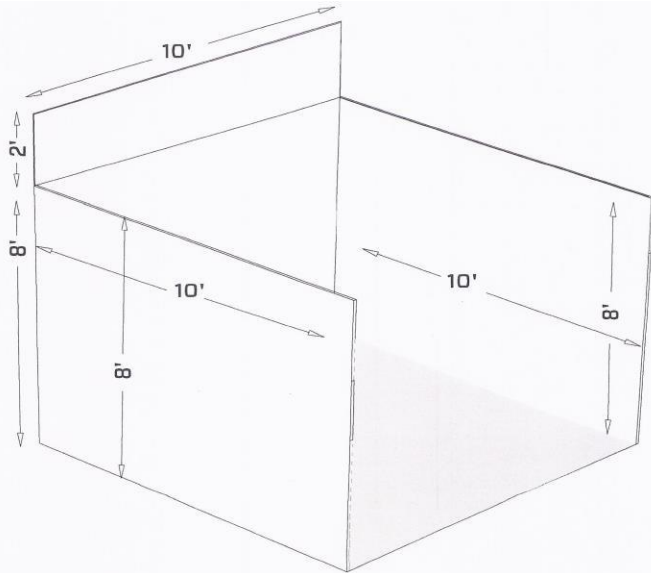



## SECURITY

Security is provided by the Prime Osborn Convention Center and guards will be on duty 24 hours throughout the event. Every reasonable precaution will be taken to protect exhibitors' property, but Show Management assumes no responsibility for any losses due to fire, theft, robbery, damage, accident or other causes.

---

## INSURANCE

Show Management is insured against public liability and property damage claims arising out of the conduct of the show. This insurance does not cover exhibitors' property, which is placed on display at the exhibitor's risk. Please refer to items #4 and 5 on your exhibitor contract/application or contact Show Management if you have questions.

---

## SHIPPING INFORMATION

Veal Convention Services charges a drayage fee for handling any materials delivered to the convention center. Deliveries without company name and booth number will be declined. Contact Veal Convention Services if you are sending shipments ahead of your arrival. Marketplace Events and Prime Osborn Convention Center are not authorized to accept your shipment. Delivery address:

Veal Convention Services  
c/o Prime Osborn Convention Center  
1000 Water Street  
Jacksonville, FL 32204  
**Company name and booth number.**

**\*ALL DELIVERIES COMING TO THE PRIME OSBORN CONVENTION CENTER FOR YOUR COMPANY MUST BE PICKED UP THE SAME DAY AS DELIVERED!**

---

## PARKING

Exhibitor parking is located in the North Parking Lot 2 and 3, grass lots located between W Forsyth Street and W Adams Street during show days. An exhibitor badge and purchased parking pass is required for entry into the lot. Parking passes can be purchased in advanced & during move-in.

All exhibitor vehicles without a Disabled Parking Permit must be removed from the West Lot Parking lot on Bay street by Wednesday, September 29, 2021 at 9pm. See diagram on the following page.

Northwest Lot-  
Exhibitor Parking  
75 Spaces



Private  
Parking  
Lot  
(grass lot)  
270 spaces

Exhibitor  
Pavilion Lot  
(gated, grass  
lot)  
75 spaces



Administrative Lot

