

JACKSONVILLE
**HOME
+ PATIO
SHOW**

Exhibitor Manual

Prime Osborn Convention Center



September 27th – 30th, 2018

This Exhibitor Manual has been compiled to help you and your staff with complete details about all phases of the exhibition process at the Jacksonville Home and Patio Show

Enclosed you will find helpful information to make your participation in our show successful.

We strongly urge that you give this manual to those having responsibility for your participation in the show.

JacksonvilleHomeShows.com

MARKETPLACE | EVENTS
Largest Home Show Producer | in North America

SHOW MANAGEMENT

The Jacksonville Home and Patio Spring Home Show is produced and managed by:

Marketplace Events
6052 Turkey Lake Rd. Suite 170
Orlando, FL 32819
Tina Robinson, Show Manager
P: 877-871-7469 Ext. 14
TinaR@MPEShows.com
www.Marketplaceevents.com

SHOW FACILITY

The Jacksonville Home and Patio Spring Home Show is held at the Prime Osborn Convention Center

1000 Water Street
Jacksonville, FL 32204
P: 904-630-4800
www.JaxEvents.com
Kelsey Hendricks, Event Manager
KHendricks@SMGJAX.com

UTILITIES

Electricity, Telephone, Water, etc.
These services are provided by the Prime Osborn Convention Center

Main: 904-630-4010
Fax: 904-630-4029

[Advance Order Deadline: September 17, 2018](#)

MOVE-IN | MOVE-OUT DAYS AND HOURS

ALL ACCOUNTS MUST BE PAID IN FULL BEFORE YOU MOVE-IN

For safety reasons, no one under the age of 16 is permitted in the halls or dock areas during move-in/out.

General Move-In Dates/Time

Tuesday	September 25, 2018	8:00am - 5:00pm
Wednesday	September 26, 2018	8:00am - 5:00pm

The following booths cannot move in until the dock doors are closed on Wednesday afternoon.

815, 817, 819, 821, 823, 825, 831, 833, 835, 837, 845, 847, 849

Please check with your sales consultant for exact times.

Dock doors will close at 5pm on Tuesday and Wednesday. Exhibitors can enter through the security entrance (Door 1) until 7pm. Move-in must be completed by Wednesday September 26, 2018.

Forklifts are available to assist with move-in. Check in with Show Decorator to arrange forklift or cart service.

Exhibitors must use Door 1, Door 6, and Door 7 to access the show floor during move in. Please do not use any other doors.

PROPPING DOORS OPEN IS STRICTLY PROHIBITED

General Move-Out Dates/Time

Sunday	September 30, 2018	6:30pm - 10:00pm
Monday	October 1, 2018	8:00am - Noon

*All exhibit material must be out of the convention center by noon on Monday March 5, 2018. Your space must be clean of all debris. If any materials are left behind, your company will be subject to a removal and cleaning fee. Marketplace Events is not responsible for any materials that are left in the building.

You may use your own carts, hand trucks, dollies, etc.

Dismantling your booth prior to show close at 6:00pm on Sunday is strictly prohibited. Your cooperation is appreciated.



SHOW HOURS

Thursday	September 27, 2018	11:00am – 9:00pm
Friday	September 28, 2018	11:00am – 9:00pm
Saturday	September 29, 2018	10:00am – 9:00pm
Sunday	September 30, 2018	10:00am – 6:00pm

Exhibitors may enter the show one hour before opening.

EXHIBITOR BADGES

Exhibitor badges are NOT mailed out prior to the show. Badges can be picked up in the Show Office Room 106 which is downstairs during move-in & during the show. Plastic badge holders are provided.

Exhibitor badges are required to identify you as an authorized exhibitor. Exhibitors will not be allowed access to the show floor during show days without a badge.

Six (6) exhibitor badges are provided for each 100 square feet of space purchased, with a maximum allotment of 24 badges per company.

If you have different staff members working your booth on different days, you are encouraged to drop off your badge each night at the exhibitor check-in desk so that your company does not run out of badges during the show.

**EXHIBITOR BADGES MUST NOT BE USED AS ADMISSION TICKETS AND CANNOT BE LEFT AT WILL CALL
EXHIBITOR ENTRANCE WILL BE OPEN EACH SHOW DAY ONE HOUR BEFORE THE SHOW OPENS**

SHOW OFFICE

During move-in, show hours & move-out, Show Management will maintain an office in the Convention Center. The office is located in meeting Rm 106 downstairs. Look for the show office sign.

EXHIBITOR ENTRANCES DURING SHOW HOURS

During show hours, exhibitors may use Door #7 which is adjacent to the parking lot on the side of the building or the Exhibitor Entrance which is located across the courtyard to the left of the main entrance. Follow the signs to this entrance and/or refer to the show floor plan. An exhibitor badge will be required to enter the show floor. **Prime Osborn Convention Center Security requires bag check to enter the building during show days.**

The main entrance is for attendees and gets very crowded prior to opening each morning. You will not be allowed to bring in exhibit supplies through this entrance, including hand-carried items.

COMPLIMENTARY TICKETS

Each exhibitor will receive 10 complimentary tickets for each 100 square feet of space purchased with a maximum allotment of 40 tickets. These will be mailed out three weeks prior to the show. Tickets will only be mailed out if your account has been settled in full.

COMPLIMENTARY TICKETS ARE NOT PERMITTED TO BE DISTRIBUTED AT THE ENTRANCE TO THE SHOW. Use your tickets to invite potential customers to the show, as a thank you to good customers or for friends and family.

MARKETING OPPORTUNITIES FOR EXHIBITORS

Please visit our website www.JacksonvilleHomeShows.com and click on Marketing Opportunities at the bottom of the home page to take advantage of our many affordable marketing opportunities that will maximize your investment in the show, and drive traffic to your booth. You may also contact your Sales Consultant directly.

WILL CALL

Will Call will be set up at the main entrance of the show in the box office. Please leave your tickets in INDIVIDUALLY marked envelopes with FIRST AND LAST NAME on the front of the envelope at Will Call for your guests.

EXHIBITOR BADGES ARE FOR EXHIBITORS, THEY ARE NOT TICKETS TO THE SHOW. THEY SHOULD NOT BE LEFT AT WILL CALL TO BE PICKED UP BY ATTENDEES.

DECORATOR SERVICES

Hale Northeastern is the show decorator and provides carpet, tables, chairs, cleaning, signage, etc.

Please order these items directly from them. The forms are available on our website www.JacksonvilleHomeShows.com under "Exhibitor Kit" at the bottom of the home page.

PARKING

Exhibitor parking is located in the gated lot on Bay Street during show days. An exhibitor badge and purchased parking pass is required for entry into the lot. Parking passes can be purchased in advanced & during move-in.

UTILITIES AND SERVICES POLICY

The Prime Osborn Convention Center is happy to provide utilities and services at prevailing rates. Current rate sheets for labor, equipment rental and services are available on request. For safety reasons, Prime Osborn Convention Center personnel must perform installation of all utility services.

Please submit all service order forms with full payment enclosed to the Prime Osborn Convention Center. They cannot provide the service until payment is received. To receive the lower advance rate, your forms must be received 7 business days prior to your first scheduled show day.

FOOD AND BEVERAGE SAMPLING

All food sampling must be approved by Savor Jacksonville. Beverage sampling is limited to 4oz and food samples are limited to 2oz. A written description that outlines the product and portion size to be sampled shall be submitted in advance to Savor Jacksonville.

Forms for all the above services can be found on our website www.JacksonvilleHomeShows.com
Click on "Exhibitor Kit" at the bottom of the homepage.

VEHICLES IN EXHIBITS

If you plan on having a vehicle in your booth as part of your display, please contact Show Management for approval and move-in instructions.

- Visqueen must be put down on the floor before the vehicle is driven into place.
- All vehicles must have a locking gas cap or gas cap sealed with tape and no more than 1/4 tank of gas in the vehicle.
- A set of keys must be left with Show Management for the duration of the show.
- All vehicle batteries must be disconnected and cables taped.

BOOTH INFORMATION, RULES & REGULATIONS

Exhibit booths will have an 8' draped back wall. On each side, a draped side rail will extend from the back of the booth to the front of the booth at a height of 32". The drape color is black. Tables, chairs, electricity etc. **are not included** with the cost of your exhibit booth.

Flooring

Flooring is not included in the cost of your exhibit booth. **For those exhibitors booked in Section 6 it is mandatory that all exhibit booths are carpeted or have some type of clean, professional-looking floor covering that covers 100% of the booth's square footage.** Sections 1 -5 are carpeted areas of the convention center.

Table Skirting

It is mandatory that all tables are properly skirted. Skirting must go from the edge of the table to the floor on all four sides. All skirting must be pressed and neat. **Use of plastic table cloths, sheets, shower curtains or any type of "makeshift" table cloths is not permitted.** We strictly enforce this and will skirt all incorrectly skirted tables at the exhibitor's expense.

All inventory and personal items must be stored **COMPLETELY OUT OF SIGHT**. Your booth should look professional and inviting to the attendee.

Staffing Your Booth

All exhibitors are expected to be in their booths during all published show hours, as we do receive consumer complaints about un-manned displays. **Our visitors pay an entrance fee and expect to be able to do business with our exhibitors at any time during show hours. If you are in violation of this rule, your company may not be permitted to exhibit with us in the future.**

Working in the aisles or distributing brochures, etc. from any other area other than your booth is prohibited. All activity must take place inside your contracted space.

Booth Guidelines

Exhibitors are allowed to build their booth to the maximum height of 8 feet. This includes back wall and sidewalls. If your display includes a sign attached to the back wall, you must get approval from show management and the following rules apply:

- TOTAL HEIGHT OF SIGN MUST NOT EXCEED 2 FEET FROM TOP OF DRAPE LINE
- Sign must be single sided
- Professionally finished
- No PVC pipe allowed

If you are using side walls as part of your display they must be completely finished on BOTH sides. No exposed wires, frames, wood must be exposed for the public or your neighbor to see.

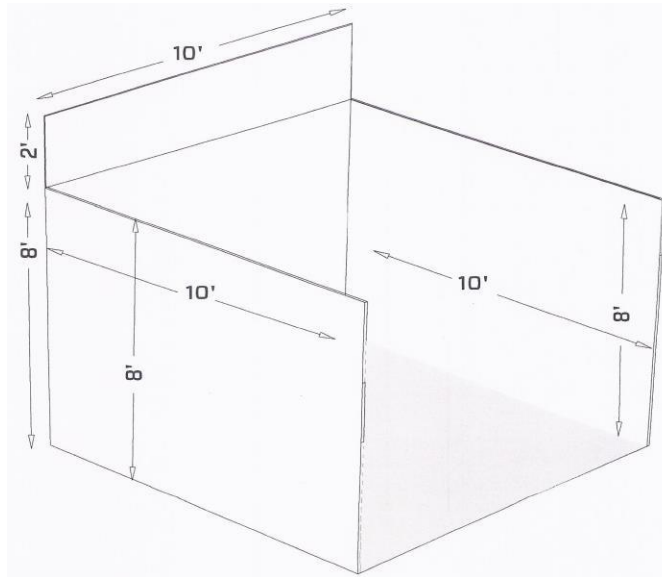

SECURITY

Security is provided by the Prime Osborn Convention Center and guards will be on duty 24 hours throughout the event. Every reasonable precaution will be taken to protect exhibitors' property, but Show Management assumes no responsibility for any losses due to fire, theft, robbery, damage, accident or other causes.

INSURANCE

Show Management is insured against public liability and property damage claims arising out of the conduct of the show. This insurance does not cover exhibitors' property, which is placed on display at the exhibitor's risk. Please refer to items #4 and 5 on your exhibitor contract/application or contact Show Management if you have questions.

SHIPPING INFORMATION

Hale Northeastern charges a drayage fee for handling any materials delivered to the convention center. Deliveries without company name and booth number will be declined. Contact Hale Northeastern if you are sending shipments ahead of your arrival. Marketplace Events and Prime Osborn Convention Center are not authorized to accept your shipment. Delivery address:

Hale Northeastern
c/o Prime Osborn Convention Center
1000 Water Street
Jacksonville, FL 32204
Company name and booth number.

***ALL DELIVERIES COMING TO THE PRIME OSBORN CONVENTION CENTER FOR YOUR COMPANY MUST BE PICKED UP THE SAME DAY AS DELIVERED!**