

# Exhibitor Manual

## Raleigh Convention Center



To our Valued Exhibitors,

This Exhibitor Manual is designed to help you and your staff with details about exhibiting in the 2022 Downtown Raleigh Home Show!

We strongly urge that you go over this manual with **ALL involved** in designing, setting up, *and* working your booth at the show.

Please let us know how we can be of service to you. Our team is here to help you have a successful show!

Our show's complete Exhibitor Kit can be found at:

**[DowntownRaleighHomeShow.com/Exhibitor-Kit](https://DowntownRaleighHomeShow.com/Exhibitor-Kit)**

# SHOW MANAGEMENT & SHOW OFFICE

The Downtown Raleigh Home Show is produced and managed by Marketplace Events. From show move-in to move-out, our show office is in room 206 of the Raleigh Convention Center.

Marketplace Events

2000 Auburn Drive Suite 200

Beachwood, OH 44122

[www.marketplaceevents.com](http://www.marketplaceevents.com)

Tina Robinson, Show Manager | P: 904-622-9140 | C: 480-290-1197 | [tinar@mpeshows.com](mailto:tinar@mpeshows.com)

The on-site show office phone number will be posted online at the start of move-in. You can also visit the Contact Us page of our show's website to reach individual team members.

# SHOW FACILITY

The Downtown Raleigh Home Show is held at the Raleigh Convention Center.

Raleigh Convention Center

500 South Salisbury St

Raleigh, NC 27601

P: 919-996-8500

[www.raleighconvention.com](http://www.raleighconvention.com)

# SHOW DECORATOR

**\*\*\*NEW for 2022\*\*\* Our show decorator has changed.** Southern Exhibition Services (SES) provides show decorator services for exhibiting in the Downtown Raleigh Home Show. For services including, but not limited to rental items (tables, chairs, booth carpeting, etc), forklift services, drayage and shipping, please refer to their complete service manual, and pricing linked on our Exhibitor Kit under Decorator Service Manual.

# MOVE-IN & MOVE-OUT INFORMATION

**PLEASE NOTE:** All accounts must be paid in full prior to move-in. For safety reasons, no one under the age of 16 is permitted in the halls or dock areas during move-in/out.

**MOVE-IN HAS CHANGED!** Please refer to the Move-In Schedule for your day and time to move into the show. Move-out procedures remain unchanged.

As a reminder, we are no longer using the lot across Lenoir St from the Red Hat Amphitheater for marshaling/check-in or parking during move-in or the show. The check-in lot is Lot G, located on W South St near the corner of S Dawson St. Please refer to the Parking section of this manual for information on parking.

## Move-In Dates & Times

If you need to drive into the convention center to move into your booth, you must check the Move-In Schedule for your assigned window (posted on the Exhibitor Kit section of the website under Move-In Schedule). If you do not need to drive into the convention center and hand carry or cart your items in, you may enter the building between 8:00am and 7:00pm on Wednesday and Thursday. At 7:00pm, the convention center doors will be locked and once you leave the building, you will not be able to get back in. If you're in the building by 7:00pm, you may stay to work until 9:00pm, at which time security will ask you to exit the building.

**Tuesday, February 22, 2022 | 1:00pm-5:00pm**

**Move-in for show staff, decorator, and large exhibits by permission ONLY;** no unauthorized exhibitors will be permitted to enter the building if you have not been pre-approved for Tuesday afternoon move-in.

**Wednesday, February 23, 2022 | 8:00am-7:00pm**

General Move-In (drive-on access ends at 5:00pm sharp, refer to Move-In Schedule for your scheduled drive-on time)

**Thursday, February 24, 2022 | 8:00am-7:00pm**

General Move-In (drive-on access ends at noon sharp, refer to Move-In Schedule for your scheduled drive-on time)

**PLEASE NOTE:** All exhibits must be show-ready on Thursday night. No move-in will be approved on Friday morning.

## Hand-Carrying & Unloading

You may use your own carts, hand trucks, dollies, etc. There are also a limited number of carts available to borrow from SES; a check-out table is located near the loading dock doors. Labor to assist with unloading/loading may be arranged at an additional charge at the SES Service Desk on the front wall of Hall A.

## Move-Out Dates & Times

Sunday	February 27, 2022	6:01pm - 10:00pm
Monday	February 28, 2022	8:00am – NOON

## Move-Out Procedures and Policies

**Breaking Down Prior to Show Close is Prohibited:** Breaking down your booth while the show is still open is a serious safety concern for attendees and extremely discourteous to your neighboring exhibitors trying to conduct business.

**Dismantling your booth prior to show close at 6:00pm on Sunday is strictly prohibited** and may result in your company being prevented from exhibiting in future shows with Marketplace Events.

**Clean Up Your Booth Space & All Construction Materials:** You must clean up and clear out everything that came in with you and dispose of all trash properly—if you have questions about disposal of large items, crates, or boxes, see the Southern Exhibition Service Desk at the front wall of Hall A or call/text MPE Operations Coordinator Erin Calabritto at (386) 334-1713.

**If you leave behind anything that requires cleanup by show management, you may be charged a cleaning fine starting at \$500.** This includes any stone, lumber, or tile debris left in the stone cutting area—cleanup fines start at \$500 for any materials left behind.

#### **Move-Out Procedures and What to Expect:**

- The rollup doors to the Loading Dock will not open until all aisle carpet is rolled up (approximately 30 minutes after the close of the show.) To expedite this process, please keep all equipment off the aisle carpet.
- Once all aisle carpet is rolled, the Loading Dock doors will open. The easiest way to move-out is to avoid the loading dock altogether and carry your items to your vehicle (if possible). If this is not possible...
- The next easiest way is to breakdown and completely pack your display. Once this is accomplished, visit the Southern Exhibition Service Desk (SES) at the front wall of Hall A to obtain a dock pass. A representative from SES will confirm that your exhibit space is ready to go and will issue a dock pass. This pass will allow access to the driveway into the loading dock basin from Lenoir Street. To be fair and keep traffic flowing smoothly, vehicles without a dock pass will not be permitted into the driveway leading to the dock basin.
- The gravel lot immediately across the street from the street is no longer available for staging. All vehicles will have to report to Lot G (same lot as you reported to on move-in) to receive a Dock Pass and possibly be held in the staging yard until dock space or floor space becomes available. Dock passes from move-in are not valid for move-out (you must check-in to get a new pass and will not be permitted into the dock basin without it).
- Please do not get in line until your booth is completely broken down and ready to go.
- If you have a larger vehicle and your booth requires a longer time to breakdown, we anticipate that by 8:00PM, the dock basin will begin to see a significant decrease in activity. At that time, conditions may allow for drive-in access to the exhibit floor.
- With your cooperation, we will try to expedite the move-out process and make it as easy as possible for everyone. We also must take into consideration safety on the show floor, maintain clear city streets, and avoid parking lot and traffic congestion. If we all work together, we can make the moveout run as smooth as possible for everyone!

# SHOW HOURS

Friday	February 25, 2022	11:00am - 9:00pm
Saturday	February 26, 2022	10:00am - 9:00pm
Sunday	February 27, 2022	10:00am - 6:00pm

Exhibitors may enter at 9:00am each day of the show; you will be required to show your Exhibitor Badge.

# EXHIBITOR BADGES

Exhibitor badges are NOT mailed out prior to the show. Badges can be picked up in the Show Office (room #206) during move-in and during show hours. Plastic pin-on badge holders are provided. Exhibitor badges are required to identify you as an authorized exhibitor. Exhibitors will not be allowed access to the show floor during move-in or show days without a badge. You do not have to wear the badge on the show floor, if you prefer to just show it at the entrance as you come and go.

Six (6) exhibitor badges are provided for each 100 square feet of space purchased, with a maximum allotment of 24 badges per company. If you have different staff members working your booth on different days, you are encouraged to drop off your badge each night in the Show Office (room #206), so that your company does not run out of badges during the show.

**IMPORTANT NOTE:** Exhibitor Badges must not be used as admission passes for guests and may not be left at Will Call for attendees. Please use your Exhibitor Tickets to invite guests to the show.

# SHOW OFFICE

During move-in, show hours and move-out, Show Management will maintain a show office in the Raleigh Convention Center. The office is located in meeting room 206 (on the mezzanine above the exhibit hall). Look for the show office sign.

# EXHIBITOR ENTRANCES

**During Move-In/Move-Out:** Exhibitors must either drive in and out through the loading dock (see move-in and move-out instructions above for how and when you can access the loading dock) or enter the Raleigh Convention Center from the street-level doors. The closest doors to the show entrance are the ones facing Cabarrus St and McDowell St. There is metered street parking on a first come, first serve basis or you may park in a nearby paid lot/garage and cart your items in and out. **Per the Raleigh Convention Center's security policies, exhibitors are no longer permitted to walk into the loading dock from behind the Red Hat Amphitheater. Use the doors to the Convention Center facing Cabarrus and McDowell.**

# COMPLIMENTARY TICKETS

**NEW for 2022:** Each exhibitor will receive 30 complimentary tickets sent three weeks prior to the show to the primary email address associated with your account. The email will contain a link and a custom code to share with your customers, prospects, friends, and family to redeem their own tickets online. **Printed tickets are no longer mailed out.**

If you would like additional electronic tickets, please email [erinc@mpeshows.com](mailto:erinc@mpeshows.com). A limited number of printed tickets are available to pick up during move-in in the Show Office on a first come, first serve basis.

**PLEASE NOTE:** These complimentary tickets are **not permitted to be distributed at the show entrance.**

## WILL CALL

If you need to leave printed tickets for a guest at Will Call, you can either redeem and print electronic tickets or you can pick up printed tickets in the Show Office. Please plan to leave your tickets in individually marked envelopes with your guest's first and last name on the front and the tickets inside. They will be filed by last name at Will Call in the Show Office for guests to pick up (tell guests to look for Show Office sign near show entrance).

**IMPORTANT NOTE:** Exhibitor Badges must not be used as admission passes for guests and may not be left at Will Call for attendees. Please use your Exhibitor Tickets to invite guests to the show.

## UTILITIES

Electricity, Telephone, Internet, Water, etc.

The Raleigh Convention Center is happy to provide utilities and services at prevailing rates. Current rate sheets for labor, equipment rental and services are available on request. For safety reasons, RCC personnel must perform installation of all utility services.

Please submit all service order forms with full payment enclosed to the RCC. They cannot provide the service until payment is received. To receive the lower advance rate, your forms must be received two weeks prior to your first scheduled move-in day.

Utilities Forms can be found under the Exhibitor Kit section of our website, which is located at the bottom of the Home Page.

Main: 919-996-8500

Fax: 919-996-8526

Internet Assistance: 919-996-8652

**IMPORTANT NOTE:** Wifi is available at no cost throughout the convention center; however, if you require internet service to transact business, we recommend ordering dedicated internet service through the facility.

# PARKING

Paid parking is available in the parking decks surrounding the convention center. Please refer to the parking map linked on our Exhibitor Kit.

Please note – commercial trucks, trailers and oversized vehicles that cannot fit in standard parking spaces are not permitted in the parking deck. Please refer to parking maps at the end of this manual. There is no parking available at the McLaurin Lot next to the Red Hat Amphitheater, as it has been sold for development and was unavailable for rental as it has been in the past. **Please do not park in the McLaurin Lot or you may be towed at your expense.** A map of available parking lots around downtown is available on the Exhibitor Kit section of our website.

# FOOD AND BEVERAGE SAMPLING

All food sampling must be approved by Centerplate, The Official Caterer of the Raleigh Convention Center, prior to the show. Food & Beverage sampling is limited to 2 oz. A written description that outlines the product and portion size to be sampled shall be submitted in advance to Centerplate. Approval of sampling arrangements will be provided to the company or organization in writing from Centerplate.

The Raleigh Convention Center holds and maintains a full-service liquor license and abides by all rules and regulations set forth by the North Carolina Alcoholic Beverage Control Commission. Outside alcoholic beverages are prohibited.

Forms for all the above services can be found on the Exhibitor Kit section of our website.

# VEHICLES IN EXHIBITS

If you plan on having a vehicle in your booth as part of your display, please contact Show Management for approval and move-in instructions.

- Visqueen must be put down on the floor before the vehicle is driven into place.
- All vehicles must have a locking gas cap or gas cap sealed with tape and no more than 1/4 tank of gas in the vehicle.
- A set of keys must be left with Show Management for the duration of the show.
- All vehicle batteries must be disconnected and cables taped.

# BOOTH INFORMATION, RULES & REGULATIONS

Exhibit booths will have an 8' draped back wall. On each side, a draped side rail will extend from the back of the booth to the front of the booth at a height of 32". The drape color is black. **Tables, chairs, and utilities are not included with the cost of your exhibit booth.**

## Flooring

Flooring is not included in the cost of your exhibit booth. **It is mandatory that all booths are carpeted** or have some type of clean, professional-looking, safe floor covering that covers 100% of the booth's square footage.

## Table Skirting

**It is mandatory that all tables are properly skirted.** Skirting must go from the edge of the table to the floor on all four sides. All skirting must be pressed and neat. Use of plastic table cloths, sheets, shower curtains or any type of “makeshift” table cloths is **not permitted**. We strictly enforce this and will skirt all incorrectly skirted tables at the exhibitor’s expense.

## Inventory

All inventory and personal items must be stored completely out of sight. Your booth should look professional and inviting to the attendee.

## Staffing Your Booth

All exhibitors are expected to be in their booths during all published show hours, as we do receive consumer complaints about un-manned displays. Our visitors pay an entrance fee and expect to be able to do business with our exhibitors at any time during show hours. If you are in violation of this rule, your company may not be permitted to exhibit with us in the future.

Working in the aisles or distributing brochures, etc. from any other area other than your booth is prohibited. All activity must take place inside your contracted space.

## Booth Guidelines

Exhibitors are allowed to build their booth to the maximum height of 8 feet. This includes back wall and sidewalls. If your display includes a sign attached to the back wall, you must get approval from show management and the following rules apply:

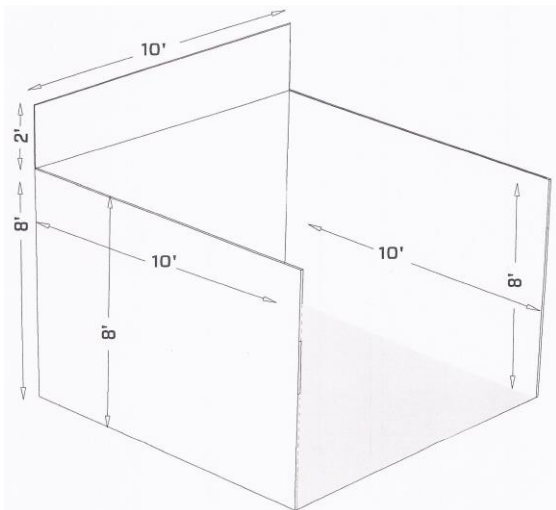

- Total height of sign must not extend higher than 2’ from the top of the 8’ drape line (10’ high maximum)
- Sign must be single sided
- Professionally finished (as a courtesy to your neighboring booths)
- No PVC pipe allowed
- **Tents and canopies are strictly prohibited—do not set them up; you will be required to take them down.**

Side walls must be completely finished on BOTH sides. No logos, exposed wires, frames, wood must be exposed for the public or your neighbor to see.

## SECURITY

Security is provided by the Raleigh Convention Center and guards will be on duty throughout the event. Every reasonable precaution will be taken to protect exhibitors’ property, but Show Management assumes no responsibility for any losses due to fire, theft, robbery, damage, accident or other causes.



# INSURANCE

Show Management is insured against public liability and property damage claims arising out of the conduct of the show. This insurance does not cover exhibitors' property, which is placed on display at the exhibitor's risk. Please refer to your exhibitor contract/application or contact Show Management if you have questions.

# SHIPPING INFORMATION

Please refer to the Southern Exhibition Services Decorator Service Manual linked on the Exhibitor Kit for shipping information, associated fees, addresses, and timelines.

# RALEIGH CONVENTION CENTER RULES AND REGULATIONS

- Metal-wheeled carts are not permitted on the stone floors.
- Bicycles and carts are allowed only on the Exhibit Hall floor and in service corridors.
- Exhibitors may not distribute stickers, decals, advertisements or similar items with adhesive backing in the building.
- Canned string, serpentine spray (e.g. Silly String), or similar products may not be used in the building.
- Glitter and confetti may not be used in the building.
- The use of helium-filled balloons or Mylar balloons is not allowed in the building.
- Only RCC personnel may move plants, lobby furniture and other RCC equipment in the public areas.
- No decorations or signage may be attached to the building walls, ceilings, columns, windows or other painted surfaces using nails, tacks, screws, wire, adhesive tape, etc.
- Sand, gravel, dirt, mulch and other loose materials may not be brought into the building without prior approval of RCC management.
- Brick, stone and other similar materials may not be cut on the premises unless a vacuum is used to prevent dust and debris from entering the air or remaining on the floor. These materials may not be glued or otherwise adhered to the facility floor.
- Holes may not be drilled, cored or punched in the building without prior written approval from your RCC Event Manager.
- Painting or applying any covering to the walls, ceilings, floors or other areas of the Convention Center, its furnishings or fixtures is not permitted.
- Spray painting, touch-up painting or use of cleaning materials (e.g. Armor All) on equipment may be done only after the exhibitor has provided adequate protection for surrounding surfaces. Exhibitors who fail to provide the protection are billed for cleanup at prevailing rates with a one-hour minimum. No painting will be permitted in any carpeted area — no exceptions.
- Drains are intended for water and sanitary waste only. Dumping of paints, food or chemical waste into sinks, toilets or other drains is strictly prohibited.



# RED HAT AMPHITHEATER



## LOCATION MAP

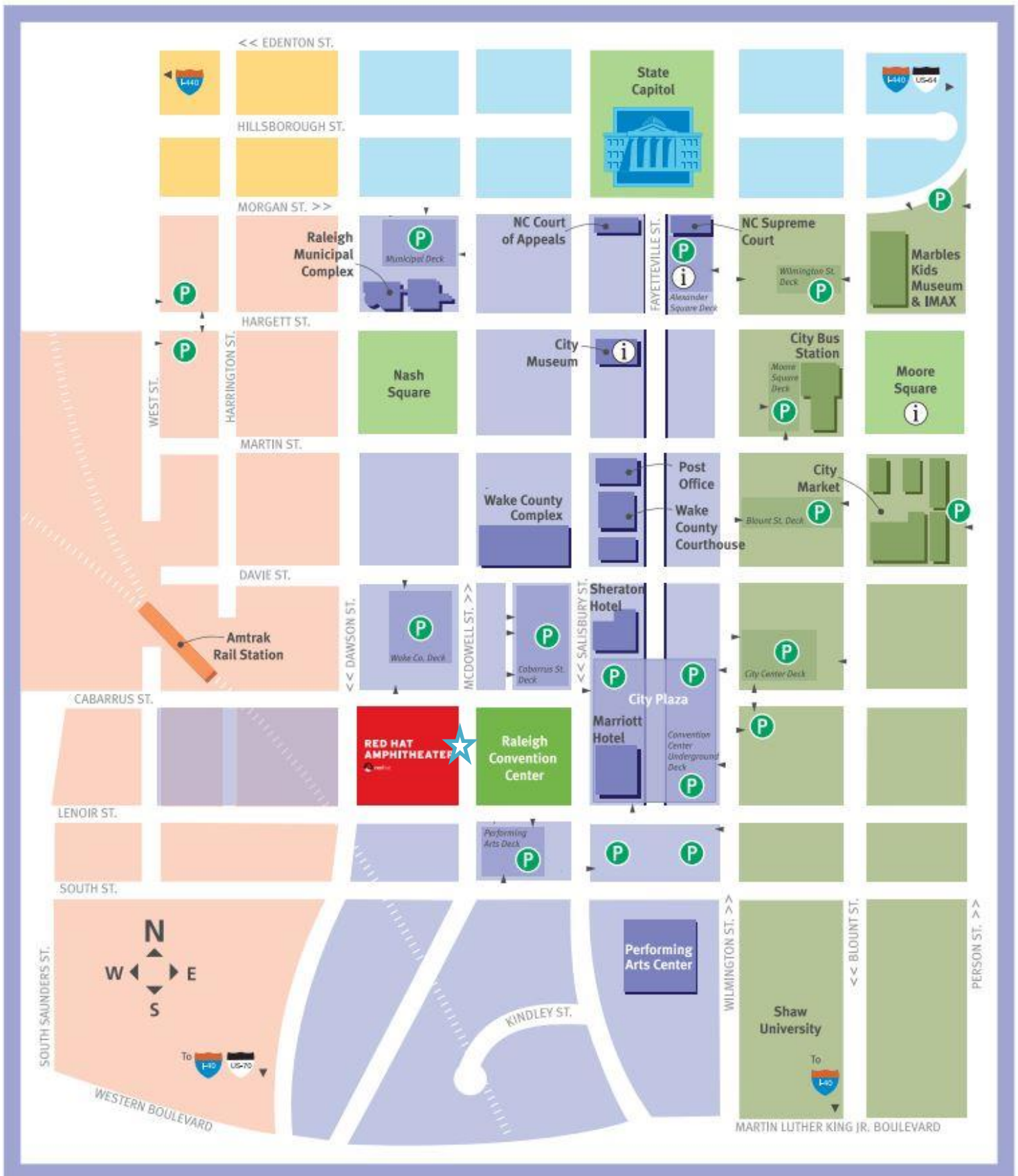

## Unloading & Parking at the Raleigh Convention Center

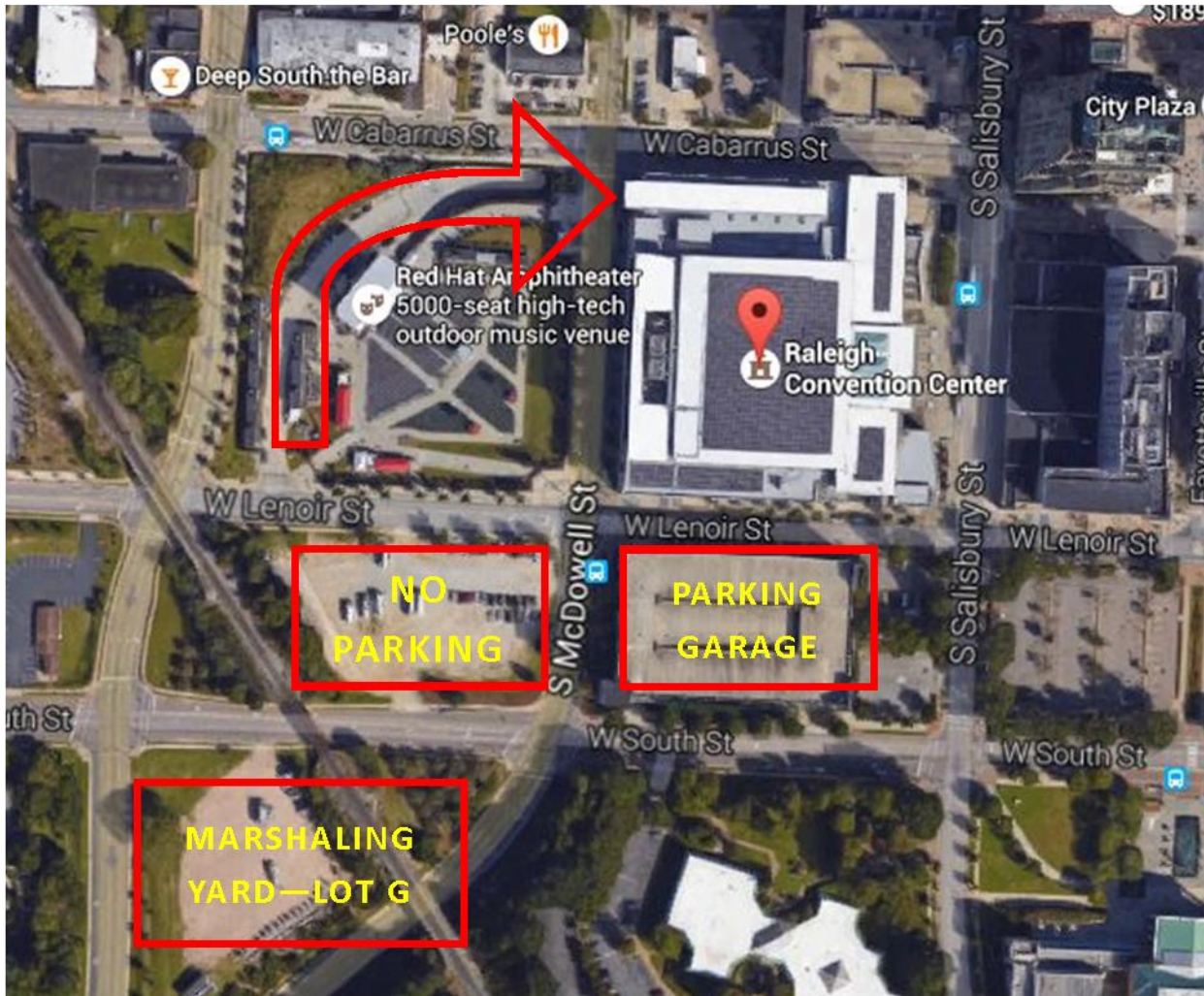

### **PLEASE READ: PARKING & UNLOADING PROCEDURES HAVE CHANGED**

**Step 1:** Check in at Lot G (new marshaling yard). You will wait here until it is your turn to drive into the Raleigh Convention Center.

**Step 2:** When it is your turn, you will drive from Lot G to Lenoir Street and enter behind the Red Hat Amphitheater into the loading docks underneath the convention center.

**Step 3:** The **McLaurin Lot** is **NOT** available for parking as it has been sold for development and is no longer available for us to rent. There is metered parking available on the street surrounding the convention center, or in the nearest **parking garage** (Performing Arts Deck, typically \$7 per day). Additional paid parking is available at the downtown parking garages surrounding the facility. **Please do not park in Lot G during move-in or move-out, as it is being used as the new marshaling yard.** Thank you for your patience with these changes!