

BIRMINGHAM

HOME Exhibitor Manual

SHOW

Birmingham Jefferson Convention Complex



February 14-16, 2020

This Exhibitor Manual has been compiled to help you and your staff with complete details about all phases of the exhibition process at the Birmingham Home Show.

Enclosed you will find helpful information to make your participation in our show successful.

We strongly urge that you give this manual to those having responsibility for your participation in the show.

BirminghamHomeShow.com

MARKETPLACE | EVENTS
Largest Home Show Producer in North America

SHOW MANAGEMENT

The Birmingham Home Show is produced and managed by:

Marketplace Events | 6052 Turkey Lake Road, Ste. 170 | Orlando, FL 32819

Mari Franco, Show Manager

P: 786-564-4124

MariF@mpeshows.com

Kristi Newton, Show | Office Administrator

P: 407-363-7653 Ext. 13

KristiN@mpeshows.com

SHOW FACILITY

The Birmingham Home Show is held at:

Birmingham Jefferson Convention Complex—North Hall & East 1

2100 Richard Arrington Jr., Blvd. North | Birmingham, AL 35203

P: 205-324-5000

<http://www.bjcc.org/>

Cheryl Mitchner, Event Manager

Cheryl.Mitchner@bjcc.org

SHOW DECORATOR

Booth Furnishings: tables, chairs, carpeting, displays & labor; Forklift Service

Veal Convention Services

3016 Reverend Abraham Woods Jr Blvd. | Birmingham, AL 35203

P: 205-328-1010

Katie@vealco.com

veal.boomerecommerce.com

All service orders are placed online through the Veal ordering portal listed above. Each exhibitor will create login credentials to access the site and place orders. Please call Katie Cotney for more information.

ADVANCE ORDER DEADLINE: Monday, February 3, 2020

UTILITIES

Electric, Plumbing, Compressed Air, Natural Gas, Telephone & Internet

These services are provided by the Birmingham Jefferson Convention Complex

All service orders are placed online through the BJCC website ordering portal listed below.

Main: 205-458-8898

<https://order.bjcc.org/orders/F1802016.htm>

ADVANCE ORDER DEADLINE: Saturday, February 1, 2020

MOVE-IN | MOVE-OUT DAYS AND HOURS

Move-In - ALL ACCOUNTS MUST BE PAID IN FULL BEFORE YOU MOVE-IN

Wednesday	February 12, 2020	8:00am - 5:00pm
Thursday	February 13, 2020	8:00am - 5:00pm

Exhibitor's vehicles must form a line in the eastbound center lane on 9th Avenue in order to turn left and enter the loading dock area. Westbound traffic on 9th Avenue will **not** be allowed to turn right and enter the loading dock area. All unloading will take place at DOCK 1.

We offer 20 minutes of complimentary forklift service from Dock 1 to your booth during move in. Any additional time need must be scheduled with the Veal Convention Services and will be billed to you at current rates.

PLEASE NOTE, any requests to drive on to the show floor must be approved by Veal Convention Services and is at the Decorators discretion depending upon conditions at that time.

For safety reasons, no one under the age of 16 is permitted in the halls or dock areas during move-in/out.

Please contact Katie Cotney, at Veal Convention Services, if you need to discuss move-in dates/times for your company. Contact Katie at 205-328-1010 or email her at katie@vealco.com

You will be allowed to work in the building on move in days after 5:00pm but you must arrive before 4:30pm.

You may use your own carts, hand trucks, dollies, etc., to transport your exhibit from the dock to your booth.

Move-Out

Sunday	February 16, 2020	6:05pm - 10:00pm
Monday	February 17, 2020	8:00am - Noon

No dismantling or removal of exhibits or exhibit material will be permitted before 6:05pm on Sunday, February 16, 2020.

The dock doors will not be opened until all attendees and any children under the age of 16 have left the show floor. Aisle carpet will be removed between 6pm and 6:45pm. Please work only in your exhibit space and keep the aisles clear.

SHOW HOURS

Friday	February 14, 2020	11:00am - 9:00pm
Saturday	February 15, 2020	10:00am - 9:00pm
Sunday	February 16, 2020	10:00am - 6:00pm

Exhibitors may enter the show one hour before opening.

EXHIBITOR BADGES

Exhibitor badges are NOT mailed out prior to the show. Badges can be picked up in the Show Office during move-in and during show hours, as well as at Will Call by the East Hall entrance. Plastic badge holders are provided.

Exhibitor badges are not required during move in, but you must have it to enter the show during show hours.

Six (6) exhibitor badges are provided for each 100 square feet of space purchased, with a maximum allotment of 24 badges per company.

If you have different staff members working your booth on different days, you are encouraged to drop off your badge each night in the Show Office, so that your company does not run out of badges during the show.

**THE EXHIBITOR ENTRANCE WILL BE OPEN EACH SHOW DAY ONE HOUR BEFORE THE SHOW OPENS.
EXHIBITOR BADGES MUST NOT BE USED AS ADMISSION TICKETS AND CANNOT BE LEFT AT WILL CALL.**

SHOW OFFICE

During move-in, show hours and move-out, Show Management will maintain a show office in the BJCC. The office is located to the side at the bottom of the escalators in North Hall. Look for the Show Office sign.

COMPLIMENTARY TICKETS

Each exhibitor will receive 25 complimentary tickets. These will be mailed out three weeks prior to the show. Tickets will only be mailed out if your account has been settled in full.

If you would like extra tickets to send to your customers, check out our Free Ticket Letter Program on the Exhibitor Kit online.

COMPLIMENTARY TICKETS ARE NOT PERMITTED TO BE DISTRIBUTED AT THE ENTRANCE TO THE SHOW. Use your tickets to invite potential customers to the show, as a thank you to good customers and for friends and family.

MARKETING OPPORTUNITIES FOR EXHIBITORS

Please visit our website www.birminghamhomeshow.com and click on the "MARKETING OPPORTUNITIES" link at the bottom of the page to take advantage of our many affordable marketing opportunities that will maximize your investment in the show, and drive traffic to your booth.

WILL CALL

Will Call will be located in the East Hall at Show Entrance.

Please leave your tickets in INDIVIDUALLY marked envelopes with FIRST AND LAST NAME for your guests.

EXHIBITOR BADGES ARE FOR EXHIBITORS, THEY ARE NOT TICKETS TO THE SHOW. THEY SHOULD NOT BE LEFT AT WILL CALL TO BE PICKED UP BY ATTENDEES OR PEOPLE WORKING IN YOUR BOOTH.

DECORATOR SERVICES

Veal Convention Services is the show decorator and provides carpet, tables, chairs, cleaning, signage, etc. Please order these items directly from them. Veal ONLY accepts service orders through their online ordering portal veal.boomerecommerce.com. Each exhibitor will visit the site and will register their company and create a password to an ordering account. For questions please call 1-800-844-8325 or contact Katie Cotney Katie@vealco.com

PARKING

Parking is available at various lots around the convention complex. We advise you utilize P4 and P5 (see map on last page of this manual).

Parking is \$8.00 per day. Valet parking is available at the Sheraton Hotel or Westin Hotel.

UTILITIES AND SERVICES POLICY

The Birmingham Jefferson Convention Complex provides utilities and services at prevailing rates. Current rate sheets for labor, equipment rental and services are available on request. For safety reasons, BJCC personnel must perform installation of all utility services involving electrical, air, water, water drainage and Internet/telephone connections.

All service orders will be placed online at the BJCC's website:

<https://app.bjcc.org//ExhibitorOrderForm?lacuNum=37&Event=1902009&Type=2>

Advanced orders for discounts must be ordered and paid by February 1, 2020

FLOORING

Flooring is not included in the cost of your exhibit booth. **It is mandatory that all exhibit booths are carpeted or have some type of clean, professional-looking floor covering that covers 100% of the booth's square footage.** Carpeting, Astroturf, hardwood, tile, vinyl flooring etc., may be used.

All edges of carpeting must be secured using double sided tape on the underside of the carpet. The Fire Marshall checks each and every carpet prior to opening the show. Please make sure to take care of this. Duct tape is not permitted.

Visqueen must be placed on the floor before laying bricks, patios, mulch, etc. Do not drill holes, nail glue or affix flooring at the State Fair Park. Any damage to the flooring will be repaired at the exhibitor's expense.

TABLE COVERINGS

It is mandatory that all tables are properly skirted. Skirting must go from the edge of the table to the floor on all VISIBLE sides. All skirting must be pressed and neat. **Use of plastic table cloths, sheets, shower curtains or any type of "makeshift" table cloths is not permitted.** We strictly enforce this and will skirt all incorrectly skirted tables at the exhibitor's expense.

All inventory and personal items must be stored COMPLETELY OUT OF SIGHT. Your booth should look professional and inviting to the attendee.



Signage

All inline booths can use S-hooks to hang banners from the pipe and drape. All signage is to be one sided and not read into neighboring booths. Free-standing signs should be placed in the back half of the booth and not block neighbor's site lines.

Endcap and Islands booths are permitted to have signage higher than 8 ft. **IF they are permanently affixed** to the booth display. If signage reads into neighboring booth exhibitor will be responsible for draping the impeding side at their expense.

Rigging services are available for exhibitors in 20'x20' booth spaces or larger. Sign needs to be approved by show management; exhibitor must pay the \$500 sponsorship fee and are responsible for the rigging fees which are charged on an hourly basis.

BOOTH INFORMATION, RULES & REGULATIONS

Exhibit booths will have an 8' draped back wall. On each side, a draped side rail will extend from the back of the booth to the front of the booth at a height of 32". The drape color is black. Tables, chairs, electricity etc. **are not included** with the cost of your exhibit booth.

Staffing Your Booth

All exhibitors are expected to be in their booths during all published show hours, as we do receive consumer complaints about un-manned displays. **Our visitors pay an entrance fee and expect to be able to do business with our exhibitors at any time during show hours. If you are in violation of this rule, your company may not be permitted to exhibit with us in the future.**

Demonstrations and handouts

Exhibitors demonstrating products and/or distributing marketing materials, product samples or souvenirs are not permitted to do outside the confines of their rented exhibit area. **Working in the aisle is strictly prohibited and will be enforced by show management.**

TENTS AND CANOPIES ARE NOT PERMITTED.

Booth Guidelines

Exhibitors are allowed to build their booth to the maximum height of 10 feet. This includes back wall and sidewalls. If your display includes a sign attached to the back wall, you must get approval from show management and the following rules apply:

- TOTAL HEIGHT OF SIGN MUST NOT EXCEED 2 FEET FROM TOP OF DRAPE LINE
- Sign must be single sided, professionally finished on the back side and no PVC pipe allowed.

If you are using side walls as part of your display they must be completely finished on BOTH sides. No exposed wires or frames must be visible to your neighbor. Unfinished sides will be covered at the exhibitor's expense.

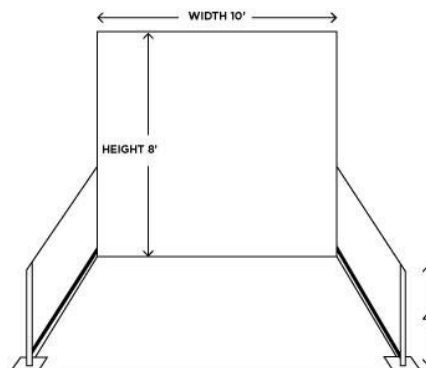

FOOD AND BEVERAGE SAMPLING

All food exhibitors must meet the operating codes of the Jefferson County Department of Health. Compliance with the Health Department must be completed prior to the opening of the show. All food must be provided in sample sizes. Please contact Cheryl Mitchner at the BCJJ for approval. Cheryl.Mitchner@bjcc.org

AUDIO/SOUND/MUSIC

Use of audio equipment, microphones and musical instruments are permitted, however sound levels must be kept at a volume that Show Management deems reasonable. Violators will receive one warning. If there is a problem with volume, Show Management reserves the right to prohibit the exhibitor from using sound equipment for the remainder of the show.

Music is **ONLY** allowed as part of a product demonstration. Unless ASCAP licensed, exhibitors are not to play music (including radio broadcast) on the show floor.

VEHICLES IN EXHIBITS

If you plan on having a vehicle in your booth as part of your display, please contact Show Management for approval and move-in instructions.

- Visqueen must be put down on the floor before the vehicle is driven into place.
 - All vehicles must have a locking gas cap or gas cap sealed with tape and no more than 1/4 tank of gas in the vehicle.
 - A set of keys must be left with Show Management for the duration of the show.
 - All vehicle batteries must be disconnected and cables taped.
-

SECURITY

Security is provided by the Birmingham Jefferson Convention Complex and guards will be on duty 24 hours throughout the event. Every reasonable precaution will be taken to protect exhibitors' property, but Show Management assumes no responsibility for any losses due to fire, theft, robbery, damage, accident or other causes.

SHIPPING INFORMATION

ADVANCE SHIPMENTS: All shipments must be pre-paid. Collect shipments will not be accepted. The last date to ship to the warehouse is Monday, February 3, 2020 to avoid late fees. Will accept until February 7, 2020 with late fees. For more information on shipping to/from the show, please contact Veal Convention Services at 1-800-844- 8325.

Label each piece as follows:

EXHIBITING COMPANY NAME

Veal Convention Services

3016 Reverend Abraham Woods Jr Blvd., Birmingham, AL 35203

Birmingham Home Show - BOOTH # _____

DIRECT SHIPMENTS: Direct shipments to the show will be accepted on/or after Sunday, February 9, 2020. Shipments **cannot arrive before 8:00am on February 10, 2020** and should be marked as follows:

Veal Convention Services

c/o Birmingham Jefferson Convention Complex

2100 Richard Arrington Jr. Blvd North Dock 1

Birmingham, AL 35203

Birmingham Home Show - BOOTH # _____

INSURANCE

Show Management is insured against public liability and property damage claims arising out of the conduct of the show. This insurance does not cover exhibitors' property, which is placed on display at the exhibitor's risk. Please refer to items #4 and 5 on your exhibitor contract/application or contact Show Management if you have questions.

Exhibitors may purchase event insurance through Buttine Exhibition & Event Insurance. Applications can be filled out online at <http://www.buttine.com/eventExhibitor.html> or visit our website, birminghamhomeshow.com and at the bottom of the page click on "exhibitor kit" for more information.

The deadline to apply is January 28, 2020

ALABAMA SALES TAX

A 4% Alabama sales tax, a 2% Jefferson County tax and a 4% city tax applies to all exhibitors who are selling a "retail" product during the show. This would mean that attendees would leave the show with the actual product.

Applicable forms and envelopes will be available at the SHOW OFFICE. Please complete all three forms and leave the envelopes in the show office.

Retail exhibitors, who are located in the Birmingham area, can elect to remit their taxes from the show at the same time as they remit their regular sales taxes. However, they need to complete the forms to say that this is the option taken. *City of Birmingham tax MUST be collected on site.

Marketplace Events is required by law to provide the Department of Revenue with a complete list of exhibitors, addresses, contacts and phone numbers. Feel free to contact each department directly.

Collectors will be on site on Sunday, February 18, 2018 to collect tax envelopes before show close.

Alabama State Tax - 4%

Contact: Sheneka Hall 205-733-2745

Alabama Department of Revenue
Sales, Use & Business Tax Division
Jefferson/Shelby Taxpayer Service Center
P.O. Box 1927
Pelham, AL 35124

City of Birmingham Tax - 4%

Contact: Titania Brown, 205-254-2497

Jefferson County Tax - 2%

Contact: Shelly Smith, 205-731-2926

BIRMINGHAM JEFFERSON CONVENTION COMPLEX

RULES AND REGULATIONS

The Birmingham Fire and Rescue Departments require the following regulations be observed at all times throughout the Complex:

- The use of untreated hay, straw, or cotton bales is prohibited.
- Flammable decorations or flammable decorative materials are prohibited.
- All draperies, drops, curtains, and table coverings used are to be noncombustible, inherently flame resistant, or treated and maintained fire resistant.
- The Fire Marshall may require proof that the materials used are fire resistant or have been treated to be fire resistant.
- Open flame, candles, torches, etc. are prohibited.
- No covered structures, such as tents, roofs, or overhead coverings, are allowed on any display in a building equipped with fire sprinklers without prior approval of the Fire Marshall.
- All utility panels, fire hose cabinets, standpipes, fire extinguishers and fire alarms must remain visible and accessible at all times.
- Drapes, decorations, buntings and other decorative materials must be fire retardant and/or properly treated to meet the requirements of flame proofing.
- Cotton batting (whether natural, artificial or manufactured) straw, dry vines, leaves, hay, pine needles and sawdust are prohibited unless treated to be fire retardant. The use of cut trees, such as Christmas trees, must have prior approval of the Fire Marshal
- Flammable liquids of any sort are prohibited in public buildings.
- Five-pound bottles of L.P. gas may be used for demonstration purposes only if approved by the Fire Marshall.
- **Cooking Displays:** Displays involving cooking with a pan or deep-frying must have a 2A-10BC rated fire extinguisher in the booth. No L.P. gas cooking is allowed.

**Our sincere thanks for your support and participation in
The Birmingham Home Show produced by Marketplace Events**

LOADING DOCKS HANDICAP

Complex Map

Complex Facilities

- A** Theatre
- B** Legacy Arena & Central Ticket Office
- C** Concert Hall
- D** North Exhibit Hall & Meeting Rooms
- E** South Exhibit Hall & Meeting Rooms
- F** East Exhibit Hall & Meeting Rooms
- G** Forum Building
- H** The Sheraton Hotel & Birmingham Ballroom
- I** The Westin Birmingham

Parking Key **P**

- P1** 9th Avenue Parking | 100 Spaces
- P2** 19th Street | 40 Spaces
- P3** 11th Avenue | 22 Spaces
- P4** East Parking Garage | 250 Spaces
- P5** 22nd Street Parking Deck | 1500 Spaces
- P6** Beechwell Parking Deck | 1600 Spaces
- P7** East Parking | 353 Spaces
- P8** Lot 8 | 157 Spaces
- P9** Lot 9 | 280 Spaces
- P10** Lot 10 | 120 Spaces
- P11** Lot 11 | 60 Spaces
- P12** Lot 12 | 90 Spaces
- P13** Premier Parking | 250 Spaces
- P14** West Parking | 190 Spaces

